



MCY SERIES THERMAL MASS/CYCLING AIR DRYERS

Manufacturing Forward





Mikropor began its journey in 1987 with a passion to create “tomorrow’s technology” and has become one of the leading manufacturers of atmospheric air filtration solutions and compressed air treatment systems for a variety of industries.

By closely following the latest developments in technology, Mikropor’s “Best in Class” products and solutions are appreciated by customers in more than 140 countries.

The company’s sustainable growth has been provided by its passion for innovation and commitment to quality, as well as its dedication to technology. Mikropor is an environmentally conscious company that values people, while developing products that extend the needs and expectations of customers.

With this mission, Mikropor continues to become one of the most recognized brands in the world by expanding its global penetration in the field of technological filtration and contributes to a healthier planet.

www.mikropor.com



THERMAL MASS/CYCLING

Compressed Air Dryers

kW-CY CONTROLLER

Digital Controller with New Features



MCY SERIES THERMAL MASS/CYCLING AIR DRYERS

Mikropor Air Quality Focus

Mikropor knows the importance of high-quality compressed air and provides customers with the highest quality air possible. Using clean, dry air is extremely important for most air powered applications. Moisture or contamination in the air from the compressor discharge will result in many complications to production equipment. These complications will decrease productivity and may affect the production quality of final product.

Applications

Mikropor provides an entire range of products for filtration and air purification applications to fit various market requirements (ISO 8573.1: 2010 standard). Applications include: Food production, dairies, breweries, chemical plants, pure air and clean room technology, pharmaceutical industry, weaving machines, photo labs, paint spraying, powder coating, packaging, control and instrument air, sand and / or shot blasting, general air works, microchip production, optics, process air as well as many other industries



International
Organization for
Standardization



The Refrigerant Circuit and Insulation

Mikropor exclusively uses environmentally friendly R134a refrigerant gas in the dryers. This refrigerant is suitable for both low and high temperature applications. R-134a has excellent thermodynamic properties and can operate at very low pressure compared to other refrigerants. This will in turn increase the refrigerant compressor's service life. With R-134a Mikropor dryers can operate at very high ambient temperatures. Mikropor engineers add extra capability to the heat exchangers with a superior no loss insulation system. This perfect insulation philosophy continues to the refrigeration circuit side also. Superior insulation and oversized condensers (for ultra-high ambient temperatures) enable the MCY Series Dryers to offer continuous air quality.

Mikropor MCY Series Cycling air dryers supply constant dewpoint at all flow ranges.



MCY SERIES THERMAL MASS/CYCLING AIR DRYERS

Compact Design

MCY Series Air Dryers are highly reliable, efficient, have small space requirements and offer low cost ownership. Integration of pre / post filtration within the dryer cabinet saves labour time, installation cost and valued production space. The compact size also offers flexibility and economy during transportation.



MCY Advantage

- Best-in-class low package pressure drop saves energy consumption from the supplying air compressor.
- Thermal mass technology offers stable pressure dewpoint at varying loads.
- Mikropor state of the art "3 in 1" cast aluminium heat exchanger provides unmatched longevity & cooling.
- Glycol cooling components are all stainless steel.
- 65°C Max inlet temp.



SAFETY - Electrical Cabinet Isolation

- Electrical panel separated from service areas of the dryer.
- Minimization of electrical components from refrigerant side of dryer.
- Electrical controls access without exposure high heat areas.



MCY SERIES THERMAL MASS/CYCLING AIR DRYERS

Mikropor Advanced "3 in 1" Heat Exchanger

Thermally Optimized Encapsulated Design

- Air to Air Exchanger
- Thermal Mass to Air
- Multistage Moisture Separation

High Strength Aluminium Design

Large Surface Area for Heat Transfer

Robust Cylindrical Casing

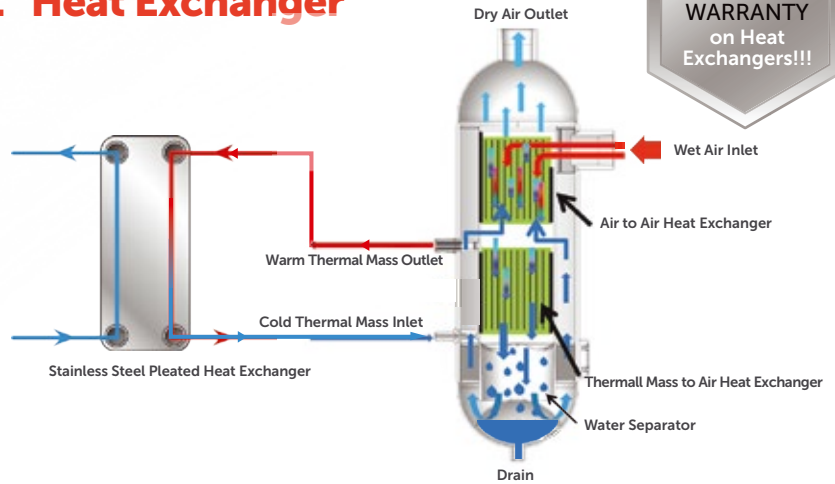

Scroll Refrigerant Compressors:

- Have fewer moving parts
- Offer smoother and quieter operation
- And are more reliable and more efficient than reciprocating types.

MCY Cycling Series-Working Principle

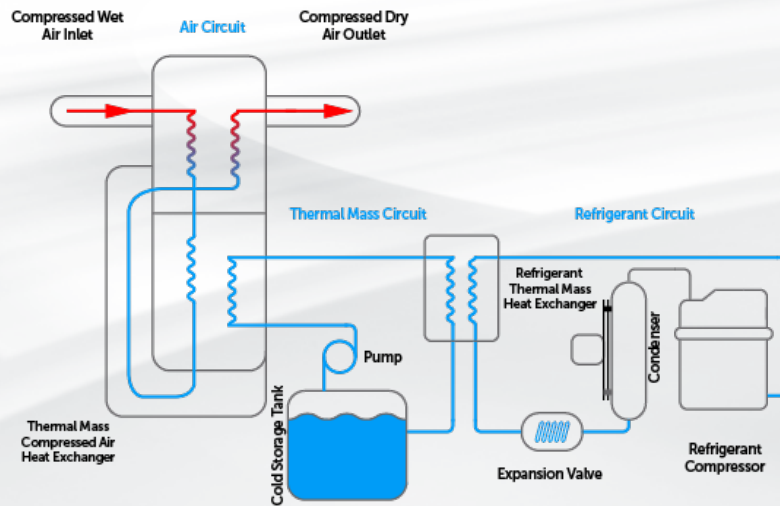

Moisture saturated Compressed Air from the Air Compressor enters a Particulate Pre-Filter then into the Thermal Mass Dryer-Compressed Air Travels through a Coalescing Pre Filter and then 3 in 1 Heat Exchanger.

As the compressed air passes through, it is then cooled by the cold Thermal Mass System and water vapor then condenses into liquid and is removed with the drain system.

Cold compressed air then passes by the incoming hot air to re-heat in order to prevent plant air pipes from sweating – then the dried compressed air passes through a Coalescing Post Filter and out to the customers application.

MCY SERIES THERMAL MASS/CYCLING AIR DRYERS

kW-CY Controllers (495 Nm³/h to 930 Nm³/h)

Mikropor MCY Series Air Dryers incorporate exclusive Digi-Pro series controller. The kW-CY digi-Pro controllers have outstanding technology for both functionality and durability in addition to visual appeal. The new controller design offers ease of adjustment with one finger, with accurate digital dew point display. In addition to coded alarm monitoring of the dryer.

Digital controller with embedded features

- Digital dew point monitoring
- Periodic maintenance interval display
- Status report
- Hours run meter
- Fahrenheit and Centigrade selection



Easy Service

Easy access into the cooling components in seconds by the help of "easy lift" panels with integrated finger slots. Simplifies service access with quick access by technicians (no screws / fasteners to remove).



kW-CY ESD Controller (1200 Nm³/h to 12500 Nm³/h units)

Mikropor MCY Series Air Dryers of larger capacity have ESD Digital Controller. With the help of the highly engineered kW-CY ESD Controller on the MCY Series Cycling Air dryers reduce energy consumption. The ESD interface assists the users to monitor many useful parameters on the dryer and guides them to troubleshoot any problem very easily. During the nights, weekends and holidays many companies do not stop their dryers although the compressors may be stopped. kW-CY ESD Controller saves huge amounts of money by simply shutting the dryer down automatically when it is not in use.



Grooved Couplings and Fittings

- The compressed air circuit utilizes grooved couplings and fittings to ensure a positive connection without leaks.
- These couplings assist the service technician to dismantle and assemble pipes easily and quickly.



MCY SERIES THERMAL MASS/CYCLING AIR DRYERS

Service Safety

- The GO Series Filter integration features.
- Zero Loss Drain system integration features.
- Manual valves allow the system to be depressurized safely when service is needed.



- Integral zero air loss drain
- No compressed air Loss
- Low maintenance design
- Reliable
- Robust low operating cost
- Simple installation

Zero Clearance Compressed Air Filters with High Performance Elements

Mikropor GKON Series compressed air filters are a MCY Series dryer standard. The X Pre-Filter (coalescing filter for water removal) is used for up to 1-micron particles and the Y Post Filter (coalescing filter for oil removal) is used to remove oil down to 0.01 ppm. Listening to customer needs our engineers created a service friendly design. The Zero clearance design helps service technicians to replace the element in just a few minutes.

The MCY Series dryer / filter combination has 2 elements and 2 Viton O-rings to ensure operation of the dryers at its best performance until the next planned maintenance.



Process Air Quality Protection

Pressure drop is a large concern in compressed air. In many applications high pressure drops will cause a decrease in the pressure at the point of use which results the machines or processes not operating correctly. Presence of dirt particles and oil in the compressed air system may result in filter blockage. It is important for the end users and service technicians to recognize if there is a problem in the system. The performance of the filters directly affects the pressure drops and system performance. Therefore, it is very important that the filter elements are changed at the filter service time. MCY Series Digital Controls feature an alarm/warning indicating the appropriate time to change the filter elements. When the indication should occur, the element change will assist to avoid loss of performance and pressure drop.

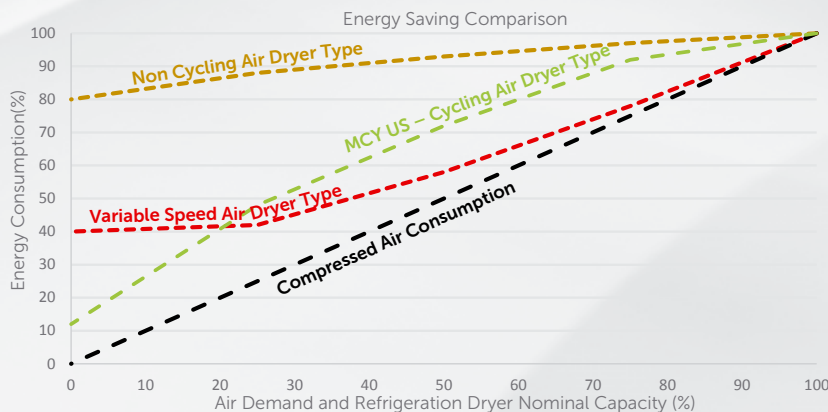

TECHNICAL SPECIFICATIONS

Correction Factor for MCY Air Dryers

Inlet Temperature (°C)	F1	Ambient Temperature (°C)	F2	Pressure (bar)	F3
30	1.29	20	1.05	4	0.80
35	1	25	1	6	0.94
40	0.92	30	0.98	7	1
45	0.78	35	0.93	8	1.04
50	0.65	40	0.84	10	1.11
60	0.45	50	0.7	12	1.16
65	0.38	-	-	14	1.22
-	-	-	-	16	1.25

Example for Choosing the Correct Dryer

If an air compressor delivers 500 m³/h at 6 bar, the dryer inlet temperature is 45°C and ambient temperature is 30°C

Please choose your dryer model as follows;
 $500 / 0.94 / 0.78 / 0.98 = 695 \text{ m}^3/\text{h}$

The correct dryer model for this application is MCY930

MCY Series - Technical Specifications

Model	Capacity (m ³ /h)	Voltage	Connection Size	Filter Quantity and Type	Replacement Filter Element Kit	Dimensions (mm)		
						Length	Width	Height
MCY-495	495	230V / 1 Ph / 50 Hz	2"	1*GKON805X + 1*GKON805Y	MKON805 KIT	857	727	1505
MCY-623	623	230V / 1 Ph / 50 Hz	2"	1*GKON805X + 1*GKON805Y	MKON805 KIT	828	728	1763
MCY-930	930	230V / 1 Ph / 50 Hz	2"	1*GKON1205X + 1*GKON1205Y	MKON1205 KIT	828	728	1763
MCY-1200	1200	230V / 1 Ph / 50 Hz	2"	1*GKON1205X + 1*GKON1205Y	MKON1205 KIT	828	728	1763
MCY-1388	1388	400V / 3 Ph / 50 Hz	3"	1*GKON-HC-1805X + 1*GKON-HC-1805Y	MKON-HC-1805 KIT	1148	798	1739
MCY-1800	1800	400V / 3 Ph / 50 Hz	3"	1*GKON-HC-1805X + 1*GKON-HC-1805Y	MKON-HC-1805 KIT	1148	798	1739
MCY-2500	2500	400V / 3 Ph / 50 Hz	3"	1*GKON-HC-2775X + 1*GKON-HC-2775Y	MKON-HC-2775 KIT	1313	878	1788
MCY-2775	2775	400V / 3 Ph / 50 Hz	3"	1*GKON-HC-2775X + 1*GKON-HC-2775Y	MKON-HC-2775 KIT	1313	878	1788
MCY-3330	3330	400V / 3 Ph / 50 Hz	DN100 Flange	1*GKO5850X + 1*GKO5850Y	GKO5850 KIT	1577	993	1976
MCY-3915	3915	400V / 3 Ph / 50 Hz	DN100 Flange	1*GKO5850X + 1*GKO5850Y	GKO5850 KIT	1577	993	1976
MCY-5085	5085	400V / 3 Ph / 50 Hz	DN100 Flange	1*GKO5850X + 1*GKO5850Y	GKO5850 KIT	1797	1077	2075
MCY-5850	5850	400V / 3 Ph / 50 Hz	DN100 Flange	1*GKO5850X + 1*GKO5850Y	GKO5850 KIT	1797	1077	2075
MCY-6875	6875	400V / 3 Ph / 50 Hz	DN150 Flange	** Externally Connected - F6500 X / Y	6*M1200 KIT	2188	1062	2024
MCY-7875	7875	400V / 3 Ph / 50 Hz	DN150 Flange	** Externally Connected - F8500 X / Y	8*M1200 KIT	2188	1062	2024
MCY-9000	9000	400V / 3 Ph / 50 Hz	DN150 Flange	** Externally Connected - F11000 X / Y	10*M1200 KIT	2247	1551	2114
MCY-10500	10500	400V / 3 Ph / 50 Hz	DN200 Flange	** Externally Connected - F11000 X / Y	10*M1200 KIT	2247	1551	2114
MCY-12500	12500	400V / 3 Ph / 50 Hz	DN200 Flange	** Externally Connected - F14000 X / Y	14*M1200 KIT	2547	1547	2172

** Not integrated and not included in standard package

Nominal Working Pressure	7 barg
Maximum Working Pressure	16 barg
Minimum Working Pressure	4 barg
Nominal Inlet Temperature	35°C
Maximum Inlet Temperature	50°C

Minimum Inlet Temperature	5°C
Nominal Ambient Temperature	25°C
Maximum Ambient Temperature	45°C
Minimum Ambient Temperature	5°C
Refrigerant	R134a

MCY SERIES THERMAL MASS/CYCLING AIR DRYERS



mikropor

1. OSB Oğuz Caddesi No:5 06935 Ankara / TURKEY

+90 312 267 0700 ✉ mikropor@mikropor.com

  **mikropor**

www.mikropor.com